



ECONOMICAL, ROBUST, EFFICIENT

Condair **Sigma**



Wellness and Hospitality

 **condair**



# Condair **Sigma**

The ES4 generates sterilized, hygienic, odour-free steam. Available with seven practical power levels and in three different sizes, the Condair Sigma produces between 4 - 65 kg of steam per hour.

## **Condair Sigma 4kg/h:**

Though compact, the Condair Sigma delivers all the advantages of the larger models with 4-kg steam output per hour, a mere width of 28.5 cm and total housing volume of 25 l. So it even fits into small niches and narrow cabins. Perfect for applications with limited space.

## **Durable and rugged**

The high-quality finish guarantees a long service life. A robust, hot-dip galvanized housing contains Condair's time-tested steam cylinders. All in all, an affordable and highly reliable humidification solution.

## **Easy to install**

The front of the housing is removable, providing convenient access to all components. Installation and servicing work is quick and simple.

## **The Condair Sigma steam cylinder**

The exchange cylinders are designed for use with ordinary tap water. The extra-large, galvanized electrodes have proved their reliability over many years of practical use.

## **Intelligent water management**

In tandem with the electronically controlled water management system, the steam cylinder adapts perfectly to local water quality. This guarantees safe, reliable operation while reducing water consumption to a minimum. The cylinder can be changed in seconds and downtimes are kept as short as possible.

## **SC-System**

As an option, the Condair Sigma is available with the patented SC system. The SC system has an unusual, advanced feature that puts it in a class of its own.

Air is blown cyclically into the steam cylinder causing the water to swirl. This keeps the particles of limescale in the entire steam cylinder constantly in motion and prevents them from settling on the sides of the cylinder.

The formation of limescale deposits on the heating electrodes and on the bottom and sides of the cylinder is prevented.

The fine particles of scale suspended in the water are rinsed out and removed during the automatic blowdown phase.

When the blowdown process is complete, the system is automatically refilled with fresh water and no interruption to operations.

The Condair humidifier's SC system does not prevent the formation of limescale completely but it does make the interval between services significantly longer.

Long life steam cylinder



### Connection options

- Steam generator [1]
- Steam connector [2]
- Water drain connector [3]
- Water supply connector [4]
- Water connection hose [5]
- Manometer [6]
- Filter valve [7]
- Funnel with siphon [8]
- Water drain hose [9]
- Service switch heating voltage supply [10]
- Service switch control voltage supply [11]
- Steam hose [12]
- SPA Display [13]
- Condair Delta SPA Control Box [14]
- Service switch Condair Delta SPA Control Box [15]

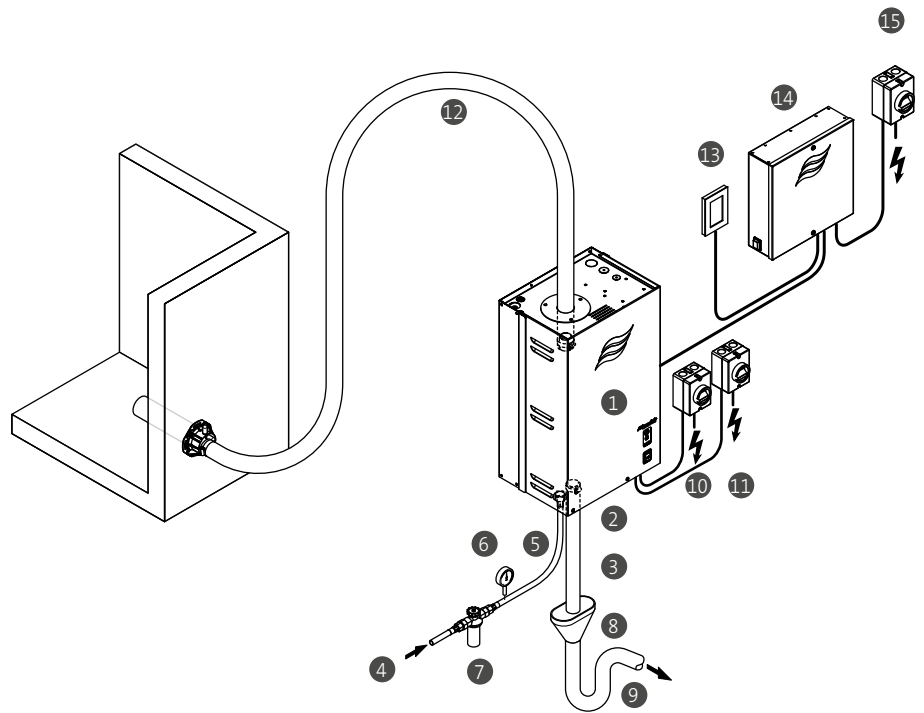

### Options

- Overpressure set
- Terminals heating voltage (THV)
- Steam hose connector with condensate trap
- Cable glands
- Internal control voltage (CVI)
- Transformer (400 V/230 V)
- 24 VDC power supply
- RFI
- SC- System
- Silence

### Technical data

Condair Sigma		4	5	8	15	23	32	45	65
Heating voltage		max. steam output in kg/h							
400 VAC / 3Ph / 50..60Hz*	Type	-	534	834	1534	2364	3264	4564	6584
400 VAC / 2Ph / 50..60Hz	Type	-	524	824	-	-	-	-	-
230 VAC / 3Ph / 50..60Hz	Type	-	532	835	1532	2362	3262	-	-
230 VAC / 1Ph / 50..60Hz	Type	422	522	822	-	-	-	-	-
Unit size		small	medium			large			
Dimensions (W x H x D)	mm	285x499x205		377x681x279			492x739x351		
Operation weight	kg	13	24	24	30	65	65	65	65
Conformity		CE, VDE, GOST							
Control voltage		230 VAC / 1 Ph / 50..60Hz							

\*other heating voltages on request